

Solar Tracking Using Micro Controller

J. Sreenivasa Reddy¹, B. Rama Bhupal Reddy²

¹Assistant Professor, Department of ECE, K.S.R.M CE (Autonomous), Kadapa-516003.

²Associate Professor and Head, Department of Mathematics, K.S.R.M CE (Autonomous), Kadapa-516003.
A.P. India.

Abstract: The aim of this paper is to acquire maximum power from solar panel and also to display the voltage generating from panel continuously. The existing work is fixed solar panels which cannot be rotated or tilted. Because of these fixed panels less amount of energy is produced. Thus we require more number of solar panels.

Keywords: Solar panels, Micro controller, Potentiometer, DC Motor

I. Introduction

This includes reducing inverter losses, storage losses and light gathering losses. Light gathering is dependent on the angle of incidence of the light source providing power to the solar cell's surface and the closer to perpendicular, the greater the power. If a flat solar panel is mounted on level ground, it is obvious that over the course of the day the sunlight will have an angle of incidence close to 90° in the morning and the evening. At such an angle, the light gathering ability of the cell is essentially zero, resulting in no output. As the day progresses to midday, the angle of incidence approaches 0°, causing a steady increase in power until at the point where the light incident on the panel is completely perpendicular and maximum power is achieved.

As the day continues toward dusk, the reverse happens and the increasing angle causes the power to decrease again toward minimum again. From this background, we see the need to maintain the maximum power output from the panel by maintaining an angle of incidence as close to 0° as possible. By tilting the solar panel to continuously face the sun, this can be achieved. *The process of sensing and following the position of the sun is known as Solar Tracking.* It was resolved that real-time tracking would be necessary to follow the sun effectively, so that no external data would be required in operation.

Over View of Embedded Systems:

An embedded system is a special purpose computer system designed to perform one or a few dedicated functions, sometimes with real-time computing constraints. It is usually embedded as part of a complete device including hardware and mechanical parts. In contrast, a general purpose computer, such as a personal computer, can do many different tasks depending on programming. Embedded systems have become very important today as they control many of the common devices we use.

An embedded system is some combination of computer hardware and software, either fixed in capability or programmable, that is specifically designed for a particular kind of application device. Industrial machines, automobiles, medical equipment, cameras, household appliances, airplanes, vending machines, and toys (as well as the more obvious cellular phone and PDA) are among the myriad possible hosts of an embedded system. Embedded systems that are programmable are provided with a programming interface, and embedded systems programming is a specialized occupation.

Certain operating systems or language platforms are tailored for the embedded market, such as Embedded Java and Windows XP Embedded. However, some low-end consumer products use very inexpensive microprocessors and limited storage, with the application and operating system both part of a single program. The program is written permanently into the system's memory in this case, rather than being loaded into RAM (random access memory), as programs on a personal computer are.

II. Microcontrollers for Embedded Systems:

In the Literature discussing microprocessors, we often see the term Embedded System. Microprocessors and Microcontrollers are widely used in embedded system products. An embedded system product uses a microprocessor (or Microcontroller) to do one task only. A printer is an example of embedded system since the processor inside it performs one task only; namely getting the data and printing it. Contrast this with a Pentium based PC. A PC can be used for any number of applications such as word processor, print-server, bank teller terminal, Video game, network server, or Internet terminal.

Block Diagram

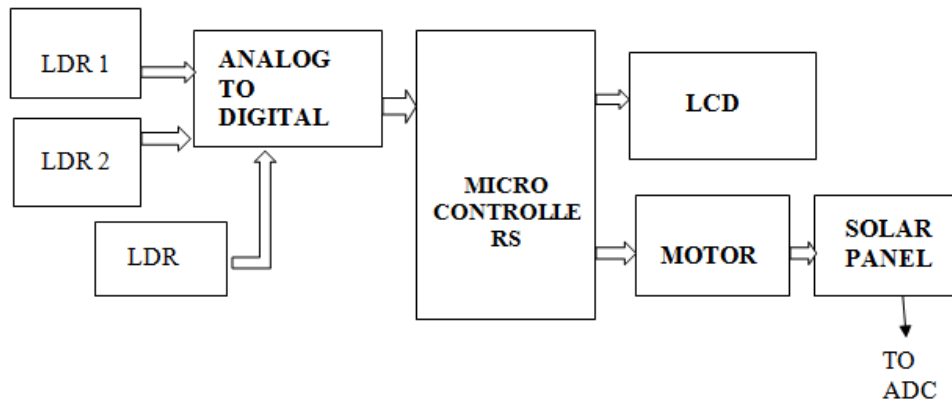

Description of AT89S52 Microcontroller:

The AT89S52 is a low-power, high-performance CMOS 8-bit microcontroller with 8Kbytes of in-system programmable Flash memory. The device is manufactured using Atmel's high-density non-volatile memory technology and is compatible with the industry-standard 80C51 microcontroller. The on-chip Flash allows the program memory to be reprogrammed in-system or by a conventional non-volatile memory programmer.

By combining a versatile 8-bit CPU with in-system programmable flash on one monolithic chip, the Atmel AT89S52 is a powerful microcontroller, which provides a highly flexible and cost-effective solution to many embedded control applications. The AT89S52 provides the following standard features: 8Kbytes of Flash, 256 bytes of RAM, 32 I/O lines, two data pointers, three 16-bit timer/counters, a full duplex serial port, on-chip oscillator, and clock circuitry. In addition, the AT89S52 is designed with static logic for operation down to zero frequency and supports two software-selectable power saving modes.

LCD:

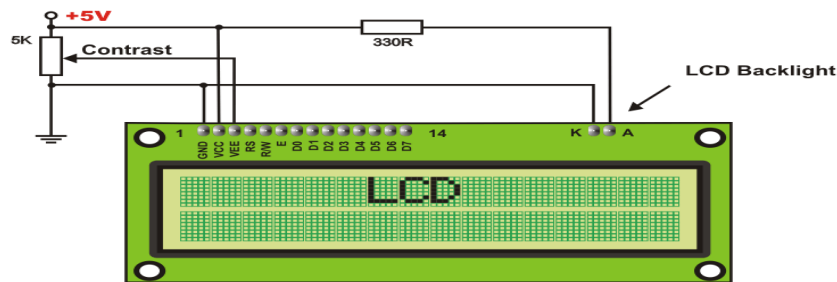

Contrast control (Potentiometer):

To have a clear view of the characters on the LCD, contrast should be adjusted. To adjust the contrast, the voltage should be varied. For this, a preset is used which can behave like a variable voltage device. As the voltage of this preset is varied, the contrast of the LCD can be adjusted.

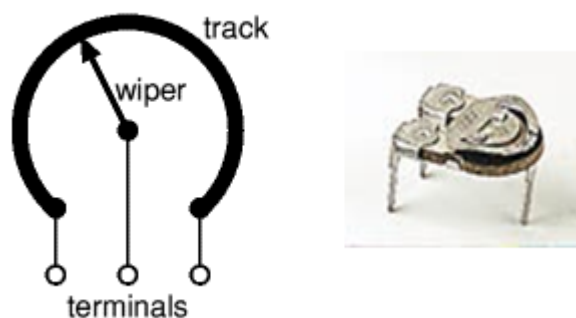

Variable resistors used as potentiometers have all three terminals connected. This arrangement is normally used to vary voltage, for example to set the switching point of a circuit with a sensor, or control the volume (loudness) in an amplifier circuit. If the terminals at the ends of the track are connected across the power supply, then the wiper terminal will provide a voltage which can be varied from zero up to the maximum of the supply.

III. DC MOTOR

Principles of Operation:

In any electric motor, operation is based on simple electromagnetism. A current-carrying conductor generates a magnetic field; when this is then placed in an external magnetic field, it will experience a force proportional to the current in the conductor, and to the strength of the external magnetic field. As you are well aware of from playing with magnets as a kid, opposite (North and South) polarities attract, while like polarities (North and North, South and South) repel. The internal configuration of a DC motor is designed to harness the magnetic interaction between a current-carrying conductor and an external magnetic field to generate rotational motion. Let's start by looking at a simple 2-pole DC electric motor (here red represents a magnet or winding with a "North" polarization, while green represents a magnet or winding with a "south" polarization).

Every DC motor has six basic parts -- axle, rotor (a.k.a., armature), stator, commutator, field magnet(s), and brushes. In most common DC motors (and all that Beamers will see), the external magnetic field is produced by high-strength permanent magnets¹. The stator is the stationary part of the motor -- this

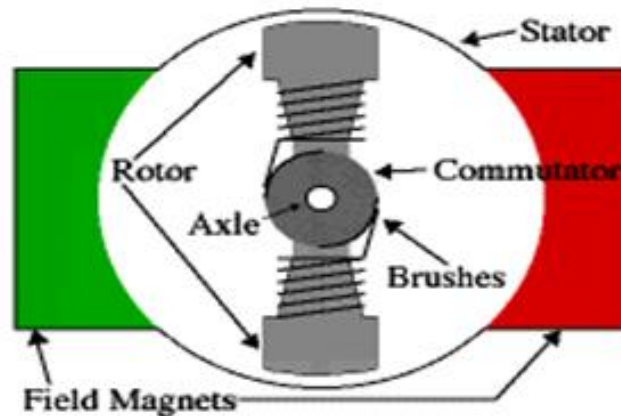

includes the motor casing, as well as two or more permanent magnet pole pieces. The rotor (together with the axle and attached commutator) rotates with respect to the stator. The rotor consists of windings (generally on a core), the windings being electrically connected to the commutator. The above diagram shows a common motor layout -- with the rotor inside the stator (field) magnets.

The geometry of the brushes, commutator contacts, and rotor windings are such that when power is applied, the polarities of the energized winding and the stator magnet(s) are misaligned, and the rotor will rotate until it is almost aligned with the stator's field magnets. As the rotor reaches alignment, the brushes move to the next commutator contacts, and energize the next winding. Given our example two-pole motor, the rotation reverses the direction of current through the rotor winding, leading to a "flip" of the rotor's magnetic field, driving it to continue rotating.

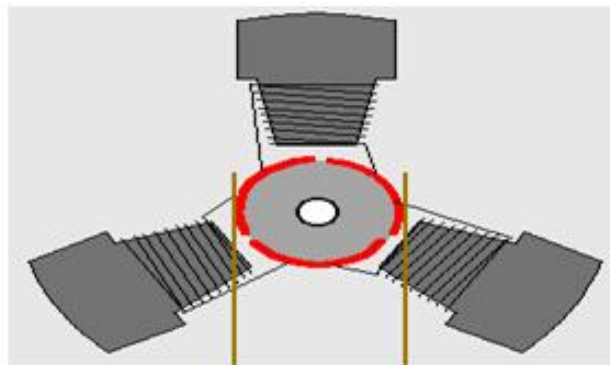

Mechanism of DC Motor:

In real life, though, DC motors will always have more than two poles (three is a very common number). In particular, this avoids "dead spots" in the commutator. You can imagine how with our example two-pole motor, if the rotor is exactly at the middle of its rotation (perfectly aligned with the field magnets), it will get "stuck" there. Meanwhile, with a two-pole motor, there is a moment where the commutator shorts out the power supply (i.e., both brushes touch both commutator contacts simultaneously). This would be bad for the power supply, waste energy, and damage motor components as well. Yet another disadvantage of such a simple motor is that it would exhibit a high amount of torque "ripple" (the amount of torque it could produce is cyclic with the position of the rotor).

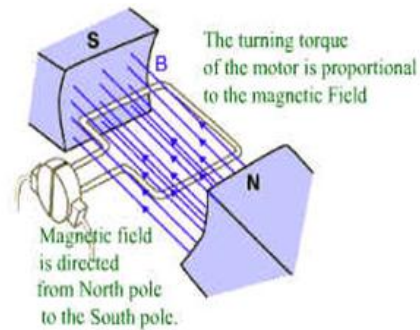
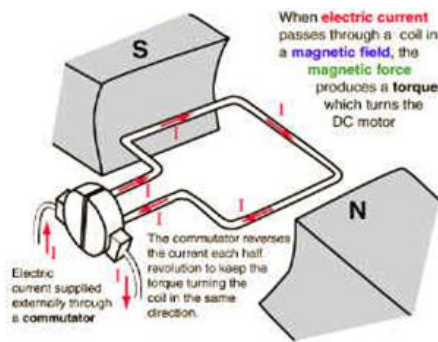

Force in DC Motor

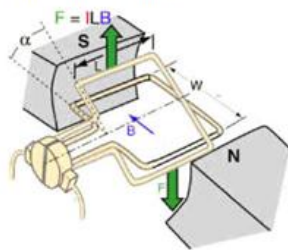

Torque in DC Motor

Magnetic Field in DC Motor

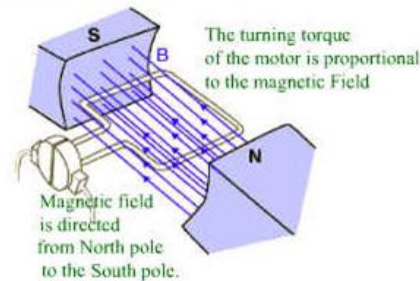

Current Flow in DC Motor

If an Electric current flows through two copper wires that are between the poles of a magnet, an upward force will move one wire up and a downward force will move the other wire down. The loop can be made to spin by fixing a half circle of copper which is known as COMMUTATOR to each end of the loop. Current is passed into and out of the loop by brushes that press onto the strips. The BRUSHES do not go round so the wire do not get twisted. This arrangement also makes sure that the current always passes down on the right and back on the left so that the rotation continues. This is how a simple Electric motor is made.

IV. L293d Driver IC

L293D is a dual H-Bridge motor driver, so with one IC we can interface two DC motors which can be controlled in both clockwise and counter clockwise direction and if you have motor with fix direction of motion then you can make use of all the four I/Os to connect up to four DC motors. L293D has output current of 600mA and peak output current of 1.2A per channel. Moreover for protection of circuit from back EMF output diodes are included within the IC. The output supply (VCC2) has a wide range from 4.5V to 36V

LDR (Light Depending Resistor):

A photo resistor, light dependent resistor (LDR) or cadmium sulfide (CdS) cell is a resistor whose resistance decreases with increasing incident light intensity. It can also be referred to as a photoconductor. A photo resistor is made of a high resistance semiconductor. If light falling on the device is of high enough frequency, photons absorbed by the semiconductor give bound electrons enough energy to jump into the Conduction band. The resulting free electrons conduct electricity, thereby lowering resistance.

ADC 0808:

The ADC0808 data acquisition component is a monolithic CMOS device with an 8-bit analog-to-digital converter, 8-channel multiplexer and microprocessor compatible control logic. The 8-bit A/D converter

uses successive approximation as the conversion technique. The converter features a high impedance chopper stabilized comparator, a 256R voltage divider with analog switch tree and a successive approximation register. The 8-channel multiplexer can directly access any of 8-single-ended analog signals. The device eliminates the need for external zero and full-scale adjustments. Easy interfacing to microprocessors is provided by the latched and decoded multiplexer address inputs and latched TTL tri-state outputs. The design of the ADC0808 has been optimized by incorporating the most desirable aspects of several A/D conversion techniques. The ADC0808 offers high speed, high accuracy, minimal temperature dependence, excellent long-term accuracy and repeatability, and consumes minimal power. These features make this device ideally suited to applications from process and machine control to consumer and automotive applications.

Solar Panels:

This work is meant to be a guide and a reference to new and old members alike who wish to know about, understand, and improve on the decisions made and processes implemented to build the current solar panels. The following paragraphs in the introduction will lay out background information on solar panels and cube satellites. This entire document was written with the idea that the reader will be able to follow the decisions made to construct the solar panels and then with this knowledge find areas of the project for improvement.

In space, the most powerful source of energy is the sun. When in day, the sun provides $1367 \frac{W}{m^2}$ of energy to the satellite [SMAD]. The trick, of course, is to harness this energy in a usable way. For about 60 years, humans have used solar cells (or photovoltaic) in order to convert this wealth of energy in the sun's rays (photons) into usable energy in the form of current (electrons). This process uses semiconductors which when excited by the photons, release a free electron that is then lose to flow as current. The principles of this conversion are not as important to understand as the fact that with all forms of energy conversion, this process has an efficiency. Manufacturing processes and material choices have improved over the years so that high grade cheaper terrestrial solar cells made from silicon can reach efficiencies of around 18% and more expensive space grade solar cells made from triple junction gallium arsenide can reach about 32% efficiency in production models [SMAD]. Some cells still in the R&D phases have been known to go up to 40% efficiency. The terrestrial models are cheaper and have less efficiency because they do not need to be as space efficient as space cells where the projects usually have extreme surface area requirements. Solar cells can be manufactured in all shapes and sizes depending on the manufacturer and the production material. Solar cells are electrically connected and mounted together to form solar arrays, also known as solar panels.

Design Process: This section is meant as a step-by-step walkthrough of the design process which took place during the Fall 2011 semester to construct the solar panels. Each decision will be discussed to the best of the author's abilities so that the reasons and facts necessary for each decision are documented and commented on. This process will follow a chronological order to best describe the choices that were made with the given information.

Constraints: The project began with a set of constraints. First, the panels had to produce the maximum amount of power. Following the goals of the satellite to provide an optical beacon in space, the satellite needs to flash as many times as possible overhead to increase the probability of being viewed from Earth. Since the satellite will not have a G&C (Guidance and Control) System, this frequency had to be high enough so that given random rotation, the satellite will still flash sufficiently toward earth to be seen when overhead. Secondly, the panels had to be cost-efficient. This constraint is enforced partially due to the prohibitive cost of buying premade solar panels because as discussed later, they cost around \$2500 and partially because this project is about engineering students making engineering decisions. Granted buying panels is a smart engineering decision because it saves time and increases reliability, but similarly, it means the team would have to spend more time fund-raising than making actual engineering choices. Thirdly, the panels must fit on the outside of the cube satellite. In space, surface area is extremely limited and on the cube sat with its size constraint, this is doubly true. To summarize, the three major constraints which the panels were designed for are optimal power, low-cost, and size. Of these three constraints, size was the most important because if the panels do not fit within the cubesat architecture then the satellite will not even be able to launch.

Size: Knowing the cube satellite size constraint limits the surface area available for the solar panels of the cube sat. Since the project mandates optimal power, the maximum amount of space available should be used so that the maximum quantity of cells can be arranged on the panel. The panels for the four vertical surfaces of the cubes at each have a side of 8.3cm x 10cm (Appendix A). Every side of the cube sat is 10cm x 10cm but the vertical surfaces have the P-Pod posts which allow the satellite to slide into the P-Pod. These posts

measure .85cm each. The top and bottom faces of the cube sat are not discussed here though panels will be designed for those sides later.

Solar Cells: The single most important decision in this process was the choosing of the solar cells. As was mentioned earlier in the introduction, two major manufactured materials exist for solar cells. The first is silicon. Silicon was the material of the first solar cells and nowadays is mostly used in terrestrial settings due to its low production cost and low efficiency. Terrestrial applications generally value cost over surface area consumed so silicon is a great fit. These cells generally range from 12%-18% efficient and come in two crystal types, mono crystalline and polycrystalline. Mono crystalline cells are usually more efficient due to the presence of just a single crystal but are a bit more expensive while polycrystalline are less expensive but generally less efficient. The second most common material used is Gallium Arsenide Solar Cells. These cells use gallium arsenide wafers instead of silicon. They are semiconductors just like silicon, but are much more efficient. The efficiency for these solar cells is about 25%-30% for production models, but some R&D cells have been known to reach 40%. Due to the extreme surface area constraint of our satellite and the desire for the most power possible, the Gallium Arsenide cells were chosen for the satellite. These cells are more expensive, but as will be shown later can still be found for reasonable prices. Also as shown above, a basic power analysis performed using the calculations covered in the Basic Power Analysis section reveals that these cells should at the very least produce enough power for adequate function of the satellite.

These solar cells are called TASC (Triangular Advanced Solar Cells) and are produced by Spectrolab. The Data Sheet, Dimensions, and Orientations for the cells can be found in Appendix B. These cells are cut from the corners of the larger Spectrolab solar cells and are basically scraps (to them). They are of similar quality to the expensive Spectro lab cells, but just do not carry the same performance guarantees. The three most important characteristics of the cells are that they are inexpensive, high efficiency, and small. The cells are sold in denominations of 50 cells at a chosen orientation (-1 or -2) for \$125 plus shipping. This price fits perfectly into the inexpensive goals of the project. Also the cells have a nominal efficiency of 27% which is a high efficiency gallium arsenide production cell. Added to that, the cells are very small so they can fit very easily into the size constraint mandated by the cube satellite and have a high packing factor. A picture is provided below of two TASC cells placed in a rectangle configuration.

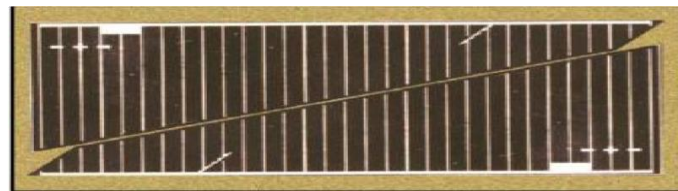

Two TASC Solar Cells

A few problems do exist with these cells though. Firstly, they are just cells. This means that the panels must be constructed to fit the cells. The cells are a little sensitive to heat so they may crack when soldering. Finally, the positive electrical connection point is on the top of the cell while the ground plane is the entire underside. Care must be taken not to electrically connect the two. Eventually the larger cells from Spectrolab may be investigated again in combination with the TASC cells since new money may be available for purchase of these cells. This new combination may produce a higher packing factor.

V. Printed Circuit Board (PCB)

After the solar cells were chosen, the problem arose of how to arrange the cells and connect them securely to the chassis. After looking at other cube satellite's solar panels such as those produced by Clyde Space and Swiss Cube, the answer was to design a printed circuit board (PCB). These boards have numerous advantages, the first of which is that they not only become the physical connection between the solar cells and the chassis but they also provide the electrical connection between cells which cut down on excess wiring that would be very difficult for novices. The boards can also be produced in quantity for cheap prices and high precision using online vendors.

Before I venture into the design process some circuit board vocabulary will be covered (REF)

- Mil or Thou = .001 inches
- Trace = Segment of conductor route
- Via = Plated through hole used to route a trace from one layer to another
- Hole = Soldering points for wires
- Pad = The portion of the conductive pattern on printed circuits designated for the mounting or attachment of components.

To design the board, ExpressPCB's design software was downloaded. Then a rectangular board measuring 8.3cm x 10cm was created. This size is the surface area available on one vertical side of the cube satellite. The maximum space was used to allow for optimal surface area usage for the panel. Next, using the cells dimensions found in Appendix B, a custom "component" which was the same size as the solar cell (orientation -2) was constructed. Since each cell will be paired with another "flipped" cell to create a rectangle, another custom component was created which used two of the previously built components to make a rectangle pair with a 50 mil separation between the two cells.

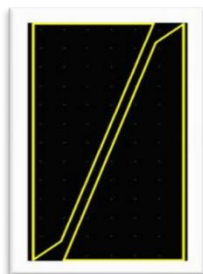

Two TASC Cell outlines created in ExpressPCB

This separation was chosen to attempt to ensure that when the cells were assembled together they would not physically or electrically touch. This could easily occur if not enough separation was present due to the imprecise, by-hand assembly process and possible excess conductive epoxy (see section on Epoxy).

When placing and arranging these cell rectangles around the PCB multiple considerations were taken into account. The maximum packing factor was desired to convert the maximum energy possible. The cells had to be far enough away from one another to have holes where wires could be soldered from the positive terminal of the cells to the PCB. Mounting holes had to be placed on each of the corners to secure the PCB to the chassis, and a common positive and negative wire had to leave the panel.

Since the nominal voltage produced by each cell is $V_{oc} = 2.52 V$ the cells had to be connected in such a way to add their voltages so that they could charge the nominal 7.5V battery pack used on the satellite. Ken Ramsley recommended that the cells be connected so that the voltage of each cell grouping was 25% higher than the nominal battery voltage. To achieve this, five cells were connected together to attain a group nominal voltage of approximately 12.5V.

To start laying out the PCB, first the amount of cells that can fit must be determined. In an ideal situation 24 cells (12 rectangle pairs) can fit on the board, but this would not leave any space for the mounting holes, or wire connections. Also the cells must be arranged in groups of 5 cells so the number of cells on each panel must be divisible by 5. Therefore, 20 cells were chosen to be placed on the board. These 10 rectangle pairs were arranged on the PCB so that enough space was left for the mounting holes, the positive/negative out wire holes, and separation between the rectangle pairs.



Arranged TASC Cells in Express PCB

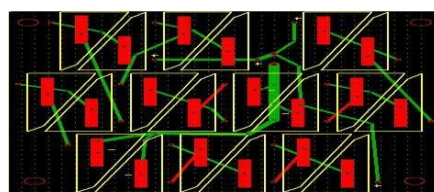

Completed PCB Design in Express PCB

The mounting holes (shown below) were chosen so that they fit #6-32 screws. After speaking with Ken Ramsley, this size screw was determined to be strong enough to secure the panels during launch. As of now, no stringent mechanical analysis has been performed. Long rectangular pads with one via inside were placed beneath every cell. These pads allowed the connection medium, solder or epoxy, to physically and electrically

secure the cell to the PCB. The via allows the electrical connection to be made to the other side of the PCB (if needed), but also acts as an anchor to physically secure the cell onto the PCB. Holes with pads were then added to the sides of each cell so that wires could be soldered from the positive terminal of each cell into the circuit board. Traces were then used to connect the cells in series into groups of 5. These groups were then all connected in parallel to the in/out terminal at the top middle-right of the board. The finished design is shown below.

VI. Solder Versus Conductive Epoxy

Two easy to use mediums exist to electrically and physically connect the solar cells to the PCB, solder paste and conductive epoxy. Solder paste consists of flux with microscale solder beads suspended inside and is primarily used for surface component mounting. The paste is placed between two metal surfaces, such as between a solar cell and a PCB pad and then passed through a solder oven. The oven melts the solder with a process called reflow soldering. The two components are then physically and electrically attached. Conductive epoxy on the other hand is an adhesive which usually contains silver. Epoxy comes in two tubes, resin and hardener, and when combined it begins to cure and eventually solidifies. Solder is a metal and therefore rigid with a very low volume resistivity (around $1.5e^{-5}\Omega * cm$). On the other hand, epoxy is a resin and therefore more forgiving, but it has a higher volume resistivity.

VII. Solar-Powered Battery Charger

The voltage of a power source indicates its ability to force electrons through an electrical circuit. When a battery is connected to a circuit (such as when you turn on the switch of a flashlight to connect its battery to its light bulb), it forces electrons out of its negative terminal (marked with a minus [-] sign), through the circuit, and into its positive terminal (marked with a plus [+] sign). This action slowly changes the chemical makeup of the battery. With use, this change reduces the voltage of the battery and at some point the battery can no longer force the electrons through the circuit. At this point we say the battery is “dead.”

For some dead batteries, another power source can be used to force the electrons to flow in the opposite direction and cause the chemical makeup of the battery to return to its original state. The battery is then “recharged.” In order to do this, the voltage of the other power source must be greater than the charged voltage of the battery.

In this lab you will use two mini-solar panels as a power source to recharge your battery.

- **Power Source:** Tape two mini-solar panels to the table and position the 150-watt lamp 120 cm above the panels. Do not place the lamp any closer, as it may melt a panel’s plastic cover. Position the lamp so it is the same distance from both panels. Turn the lamp on only when taking a measurement or testing your design.
- **Measure voltages:** Follow your teacher’s instructions on how to measure the open circuit output voltage of each solar panel and the dead battery. Record these measurements in table 1.
- **Set up an ammeter:** Set up the electromagnet and compass ammeter your team built. Using one solar panel test the ammeter to ensure it is still operational. The needle should deflect 15 to 20 degrees when the lamp is turned on
- **Design and test the battery charger:** On paper, draw a diagram showing how to connect the two solar panels, the dead battery, and the ammeter so that when the light is turned on, electrons will flow from the solar panels into the negative terminal (-) of the battery. Remember, your ammeter has been calibrated to tell you the direction in which electrons are flowing. Once you have drawn a circuit you believe will work, build and test it. If your ammeter does not show you that electrons are flowing into the negative terminal of the battery, check all of your connections. If this is not the problem, redesign your circuit. Then rebuild and retest it.

Keil Software:

Keil Compiler is a software used where the machine language code is written and compiled. After compilation, the machine source code is converted into hexcode which is to be dumped into the microcontroller for further processing. Keil compiler also supports ‘C’ language code. Keil Software is the leading vendor for 8/16-bit development tools (ranked at first position in the 2004 Embedded Market Study of the Embedded Systems and EE Times magazine). Keil Software is represented world-wide in more than 40 countries. Since the market introduction in 1988, the Keil C51 Compiler is the de facto industry standard and supports more than 500 current 8051 device variants. Now, Keil Software offers development tools for ARM.

VIII. Experimental Results

The following pictures show the view of the working of the solar tracking. Figure 1 shows us when the LDR at east side gets more light. Figure 2 shows us what happens when more light falls on the LDR which is at the west side. Figure 3 shows what happens when the light falls on the LDR which is at the middle.

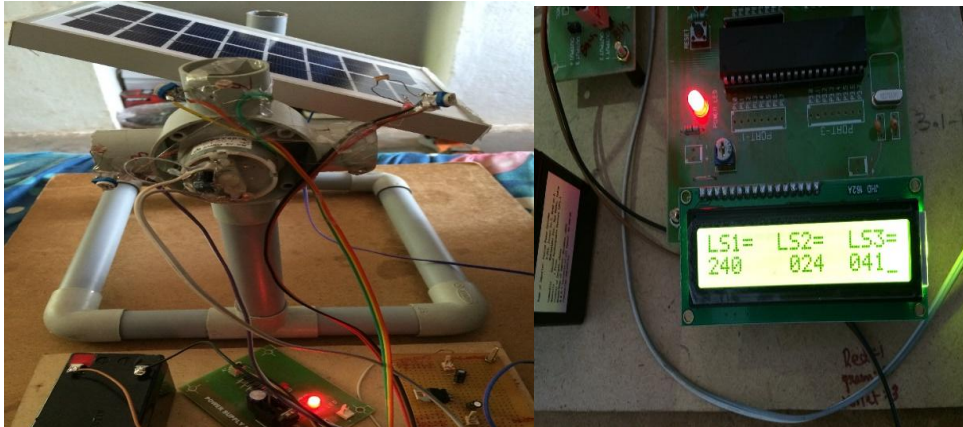

FIG 1: Panel Tilting Towards East

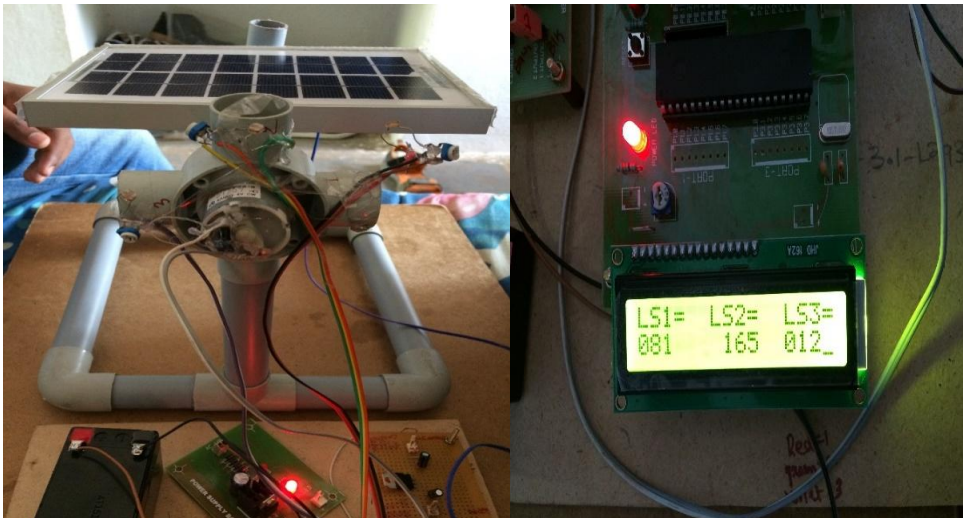

FIG 2: Panel Tilting Towards Middle

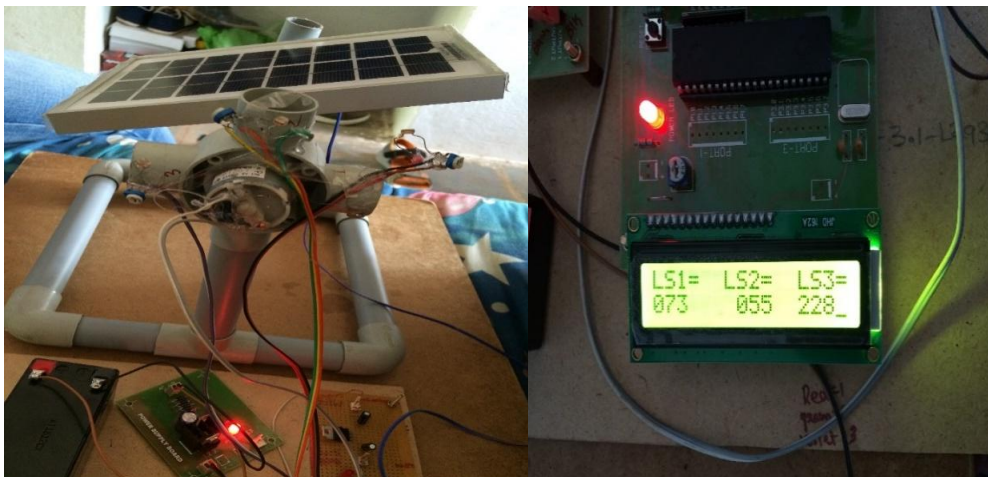

FIG 3: Panels Tilting Towards West

IX. Conclusions

A solar tracker is designed employing the new principle of using small solar cells to function as self-adjusting light sensors, providing a variable indication of their relative angle to the sun by detecting their voltage output. By using this method, the solar tracker was successful in maintaining a solar array at a sufficiently perpendicular angle to the sun. The power increase gained over a fixed horizontal array was in excess of 30%. This Paper has presented a means of controlling a sun tracking array with an embedded microprocessor system. Specifically, it demonstrates a working software solution for maximizing solar cell output by positioning a solar array at the point of maximum light intensity. This project utilizes a dual-axis design versus a single-axis to increase tracking accuracy.

X. Future Scope

The goals of this project were purposely kept within what was believed to be attainable within the allotted timeline. As such, many improvements can be made upon this initial design. That being said, it is felt that this design represents a functioning miniature scale model which could be replicated to a much larger scale. The following recommendations are provided as ideas for future expansion of this project:

- Remedy the motor binding problems due to the photo sensor leads. This could be done with some sort of slip ring mechanism, smaller gauge wire, a larger motor with more torque, or a combination of some or all of these ideas.
- Increase the sensitivity and accuracy of tracking by using a different light sensor. A photodiode with an amplification circuit would provide improved resolution and better tracking accuracy/precision.
- Different algorithm can be followed for more efficient tracking. This device can be given more intelligence, such as after tracking once, it will be able to predict the line of movement of the sun across the sky.
- User-handling can be more sophisticated, i.e. user can select the waiting time.
- A digital display can be configured along with this.

References

- [1]. D. A. Pritchard, "Sun tracking by peak power positioning for photovoltaic concentrator arrays," *IEEE Contr. Syst. Mag.*, vol. 3, no. 3, pp. 2-8, 1983.
- [2]. A. Konar and A. K. Mandal, "Microprocessor based automatic sun tracker," *IEE Proc. Sci., Meas. Technol.*, vol. 138, no. 4, pp. 237-241, 1991.
- [3]. B. Koyuncu and K. Balasubramanian, "A microprocessor controlled automatic sun tracker," *IEEE Trans. Consumer Electron.*, vol. 37, no. 4, pp. 913-917, 1991.
- [4]. J. D. Garrison, "A program for calculation of solar energy collection by fixed and tracking collectors," *Sol. Energy*, vol. 72, no. 4, pp. 241-255, 2002.
- [5]. P. P. Popat "Autonomous, low-cost, automatic window covering system for daylighting Applications," *Renew. Energ.*, vol. 13, no. 1, pp. 146, 1998.
- [6]. M. Berenguel, F. R. Rubio, A. Valverde, P. J. Lara, M. R. Arahal, E. F. Camacho, and M. López, "An artificial vision-based control system for automatic heliostat positioning offset correction in a central receiver solar power plant," *Sol. Energy*, vol. 76, no. 5, pp.563-575, 2004.
- [7]. J. Wen and T. F. Smith, "Absorption of solar energy in a room," *Sol. Energy*, vol. 72, no. 4, pp. 283-297, 2002.
- [8]. T. F. Wu, Y. K. Chen, and C. H. Chang, *Power Provision and Illumination of Solar Light*, Chuan Hwa Science & Technology Book CO., LTD, 2007.
- [9]. C. C. Chuang, *Solar Energy Engineering-Solar Cells*, Chuan Hwa Science & Technology Book CO., LTD, 2007.
- [10]. L. A. Zadeh, "Fuzzy sets," *Inform. And Contr.*, vol. 8, pp. 338-353, 1965.
- [11]. L. A. Zadeh, "Fuzzy Algorithms," *Inform. And Contr.*, vol. 12, pp. 94-102, 1968.
- [12]. E. H. Mamdani, "Application of fuzzy algorithms for control of a simple dynamic plant," in *Proc. Inst. Elect. Eng.*, vol. 121, pp. 1585-1588, 1974.